

- > Port size: G1/2 ... 1
- > Low power consumption
- > Wear-resistant ceramic rotary action sliding plate
- > Valve remains on last setting if power lost
- > Will handle contaminated fluids
- > International approvals



Technical features

Medium:
Neutral gases and liquids

Operation:
Electric motor operated

Mounting position:
Preferably with drive vertical on top ± 60°

Flow direction:
Determined

Port size:
DN 15, DN 20

Operating pressure:
See table

Fluid temperature:
-10 ... +90°C (+14 ... +194°F)

Ambient temperature:
-10 ... +40°C (+14 ... +104°F)

Material:
Body: Brass (CW617N)
Seat seal: NBR
Internal parts: Oxyd-ceramic

Approval depends on motors, see below!

Technical data – standard models

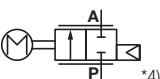
Symbol	Port size	Nominal Diameter (mm)	Operating pressure		Flow kv value *2) (m³/h)	Weight (kg)	Drawing *1) No.	Typ *3)
			(bar)	(psi)				
 *4)	G1/2	15	-0,9 ... 10	-13 ... 145	1.1	0.9	8 / 11	8288200.96xx.xxxxx
	G3/4	20	-0,9 ... 6	-13 ... 87	4.4	1.6	9 / 12	8288300.96xx.xxxxx
	G1	20	-0,9 ... 6	-13 ... 87	4.4	1.6	9 / 12	8288400.96xx.xxxxx

*1) Technical data and ordering information see following pages

*2) Cv-value (US) ≈ kv value x 1,2

*3) See motor drives for motor Cat no and power supply

*4) Throttle setting with overlap - Not gastight

Technical data – Stepping motor 9668/9678

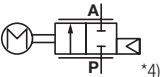
Symbol	Port size	Nominal Diameter (mm)	Operating pressure *5)		Flow kv value *2) (m³/h)	Weight (kg)	Drawing *1) No.	Typ *3) Motor in V d.c.
			(bar)	(psi)				
 *4)	G1/2	15	-0,9 ... 16	-13 ... 232	1.1	0.9	8 / 10 / 11	8288200.9668.02400
	G3/4	20	-0,9 ... 16	-13 ... 232	4.4	1,6	9 / 10 / 12	8288300.9678.02400
	G1	20	-0,9 ... 16	-13 ... 232	4.4	1,6	9 / 10 / 12	8288400.9678.02400

* 5) If operating pressure > 10 bar longer duration possible, avoid long downtimes.

Motor

Motor type	Standard voltage Tolerance ± 10% (V)	Frequency (Hz)	Power consumption (VA/W)	Protection class	Torque (Ncm)	Operating time through *6) 90° ^v (s)	Wiring diagram No.	Typ *3) Model-Motor-No.
D.c. motor	24	-	1.5	IP54	120	10 ... 14	1	9675.02400 *10)
Synchronous motor	24	50	3	IP54	120	10	3	9636.02450
Stepping motor	24	*7)	5	IP54	120	10	4	9638.02400
Stepping motor	24	-	3.3 max. 9.1	IP54	220 *8)	10 ... 11	2	9678.02400
Stepping motor	24	0	3.3 max. 9.1	IP54	120 *9)	5	2	9668.02400

*6) Operating time depends on operating pressure

*7) Nominal stepping frequency 200 Hz

*8) Short duration max. 500 Ncm

*9) Short duration max. 300 Ncm

*10) Expected to be available from November 2019

Note! All motor drives fulfil the requirements of the generic standards for electromagnetic compatibility (EN 61000-6-3:2007 + A1:2011 and EN 61000-6-2:2005) to Directive 2014/30/EU.

Limit switch service life: >100,000 cycles

Option selector

8288***.***.***.***

Port size	Substitute
G1/2	2
G3/4	3
G1	4
Cartridge	5
Valve options	Substitute
Seat seal FPM, control discs for kvs 1.1	60
Seat seal EPDM, control discs for kvs 1.1	61
Control discs for kvs 3.4 pmax. 6 bar (87 psi), only for G1/2 and cartridge models	62
Seat seal EPDM, control discs for kvs 3.4 pmax. 6 bar (87 psi), only for G1/2 and cartridge models	64
Oxygen model, assembled without oil and grease, Seat seal FPM, Valve in shut-off position not gastight. BAM-certificate not available.	75

Frequency	Substitute
See table frequency codes	xx
Voltage	Substitute
See Voltage codes	xxx
Actuators options	Substitute
See table motors	96xx

Characteristic curve

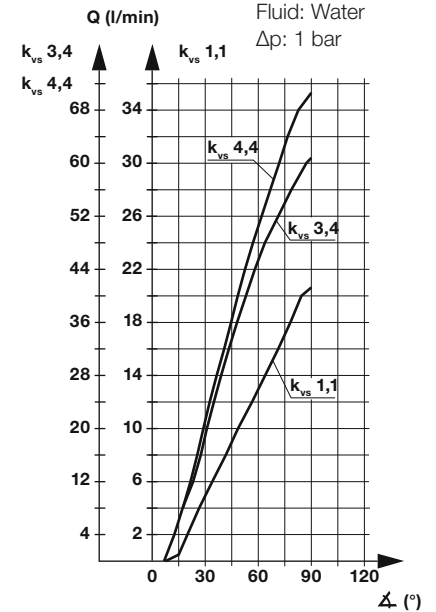



Further technical data for DC motors

Model 9675 *11)

Motor with feedback potentiometer for servo-amplifier

Feedback potentiometer	
Resistor	1 kΩ
Resistor tolerance	± 20 %
Max wiper current	1 mA
Power rating	0,1 W

Only part of the potentiometer's range is used.

*11) Expected to be available from November 2019

Further technical data for DC motors

Model 9638

Operation of the drive is possible via a stepper motor control electronics only.

Motor	bipolar
Power/phase	0.4 A constant current
Stride frequency	200 Hz
Resistance per phase	9 Ω
Inductance per phase	12 mH
Steps for opening angle of 90°	2028

Further technical data for the stepper motor drive with integrated position regulator

Model 9668, 9678

Drive with positioner electronics and analogue interface

Power supply residual ripple	Max. 1.2 Vss
Set point input	0 ... 10 V S1, S2: OFF-OFF Input resistance: approx. 200 kOhm 0 ... 20 mA S1, S2: ON-OFF Input resistance: approx. 500 Ohm 4 ... 20 mA S1, S2: ON-ON Input resistance: approx. 500 Ohm
Position feedback output	0 ... 20 mA S2: OFF Maximum load resistance 500 Ohm 4 ... 20 mA S2: ON Maximum load resistance 500 Ohm
Ripple of the input signal	Max. 40 m Vss with voltage signal Max. 0,08 m Ass with current signal
Material	Enclosure: polybutylene terephthalate (PBT) Enclosure cover: polycarbonate Output shaft: 1.4104 Output shaft seal: NBR Cover seal: CR
Required by the customer Plug connection	Cable socket, M12, A-coding 5-pin

If the load torque exceeds a peak value of 300 Ncm (9678: 500 Ncm) even for a short period, the electronics will switch off the drive and thus protect it from overloading. This error status is signalled by the illumination of a red ALARM LED on the circuit board. A brief interruption to the supply voltage confirms the error.

Wiring diagrams

d.c. motor	9675
Wiring	
+ to 1 - to 2	Direction of operation CLOSE
+ to 2 - to 1	Direction of operation OPEN

Cutoff at limits provided by microswitches
Resistance between 3 and 4:
minimum value – valve closed
maximum value – valve opened

1

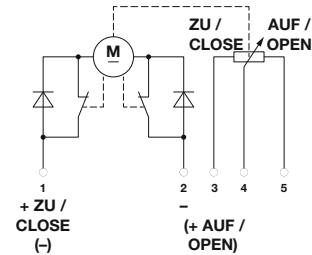

Stepping motor	9668, 9678
Pin 1	Power supply 24 Volt
Pin 2	Power supply 0 Volt
Pin 3	Reference potential for the nominal value input and the position feedback output
Pin 4	Nominal value input 0 – 10 V / 0 (4) – 20 mA
Pin 5	Position feedback output 0 (4) – 20 mA

Synchronous motor	9636
Wiring	
2 to 1 and 3 2 unused	Direction of operation CLOSE
2 to 2 and 3 1 unused	Direction of operation OPEN

Cutoff at limits provided by microswitches

2

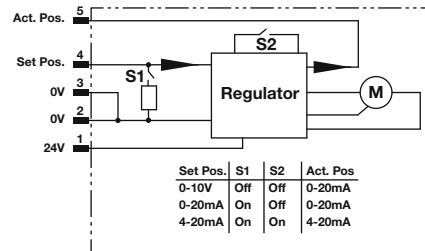

3

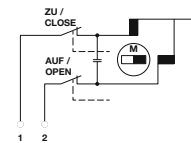

Stepping motor	9638
Wiring	
1	Motor frame (possibly for screening)
2	Reference potential for contacts
3	Limit feedback signal (OPEN) contact opened at limit
4	Limit feedback signal (CLOSED) contact opened at limit
5 and 6	Connections for phase 1
7 and 8	Connections for phase 2

4

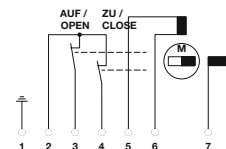

Notes on choice of motor

Buschjost offers various valve designs and a choice of DC, synchronous and stepper motors catering for the wide range of applications of the motorised valve and the customer's needs.

The mechanical contacts of DC motors make them unsuitable for control functions involving a large number of small adjustments. The AC synchronous motors last longer thanks to their absence of contacts. A stepper motor has to be used where frequent and/or fine adjustment is required. The following table shows the characteristics of the components used.

Motor design		Motor life (running life) (Count 90° cycle)	Recommended pulse duration (ms)	Recommended interval without current during reversal in direction of rotation (ms)
d.c. motor	9675 *12)	up to 90.000	> 100	600
Synchronous motor	9636	180.000	> 100	40
Stepping motor	9638	180.000	Stepping frequency 200 Hz	-
Stepping motor	9668	250.000	-	-
Stepping motor	9678	120.000	-	-

Further drive models and electronic controllers available on request

Flow regulation kit available on request

*12) Expected to be available from November 2019

Section View

8288500.96xx, Cartridge

No.	Description
*100	Valve cartridge
1000	Motor drive
9900	Cheese-head screw

* These individual parts form a complete wearing unit.

When ordering spare parts please state Cat no and series no.

Accessories

Cable socket with metal locking mechanism, Screw terminal, Enclosure and contact bodies made of PA



Connection cross-section	Cable feed-through	Plug connection	Model
0,75 mm ²	6...8 mm	M12	1704222

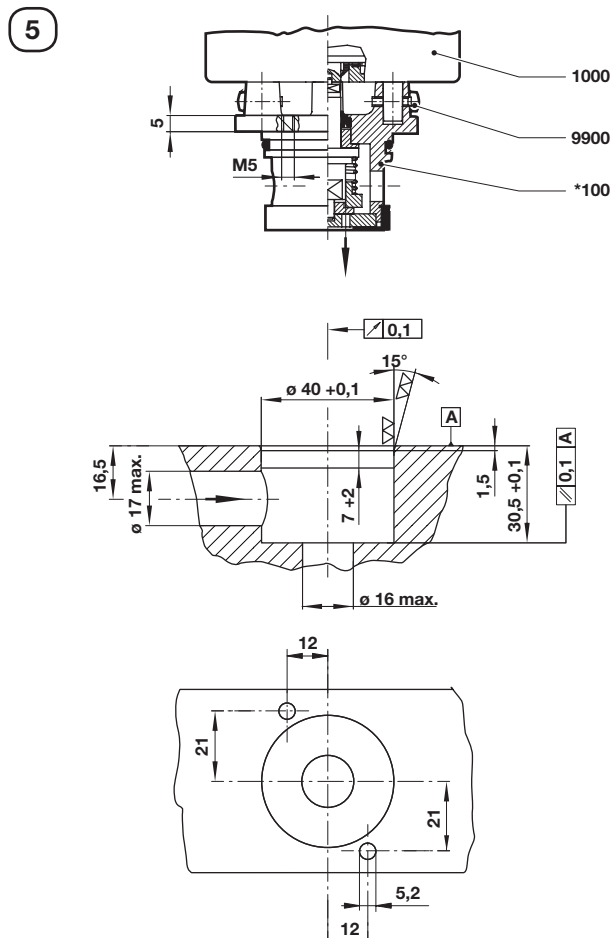

Terminal assignment

M12 plug

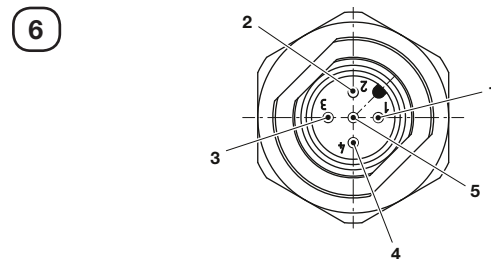

1	Power supply 24 Volt
2	Power supply 0 Volt
3	Reference potential for set point input and position feedback output
4	Set point input 0 – 10 V / 0 (4) – 20 mA
5	Position feedback output 0 (4) – 20 mA

Section View

G1/2

7

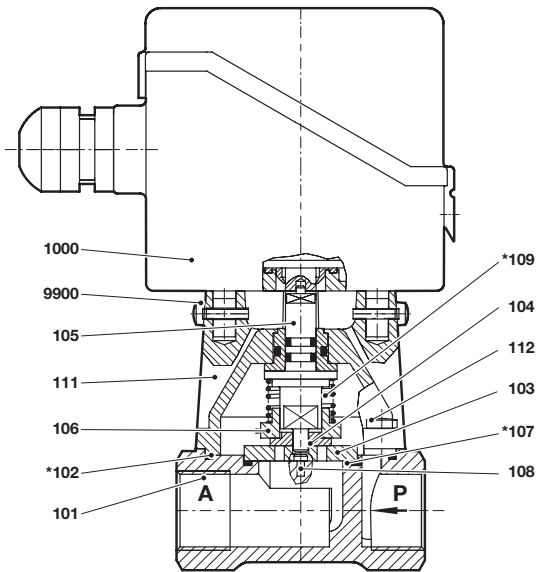

G3/4 ... 1

8

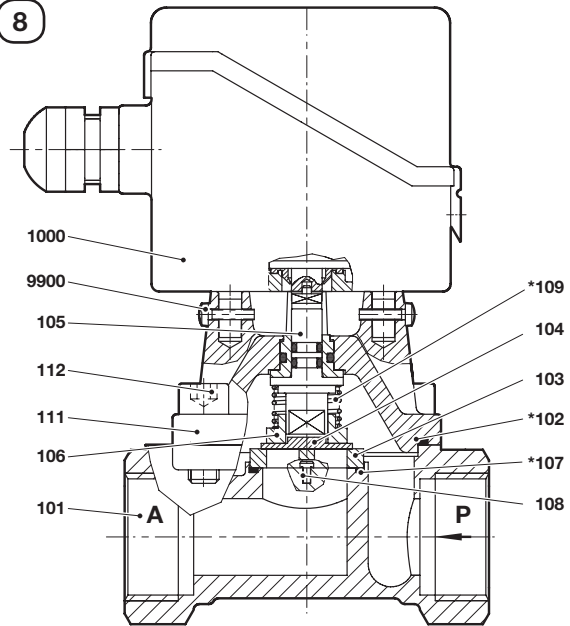

No.	Description
101	Valve body
*102	O-ring
103	Disc
104	Disc
*105	Valve spindle
106	Holder
*107	O-ring
108	Pin
*109	Compression spring
111	Body cover
112	Flat head screw (G1/2) Allen head screw (G3/4 ... 1)
1000	Motor drive
9900	Fillister-head screw

* These individual parts form a complete wearing unit.
When ordering spare parts please state Cat no and series no.

Section View

xxxxxxx.9668.02400 and xxxxxxx.9678.02400, Stepping motor

Delivery status: OFF	
1	S1 = On: 0/4-20mA Off: 0-10V
2	S2 = On: 4-20mA Off: 0-20mA
3	Programming and diagnostic interfaces
4	Alarm LED

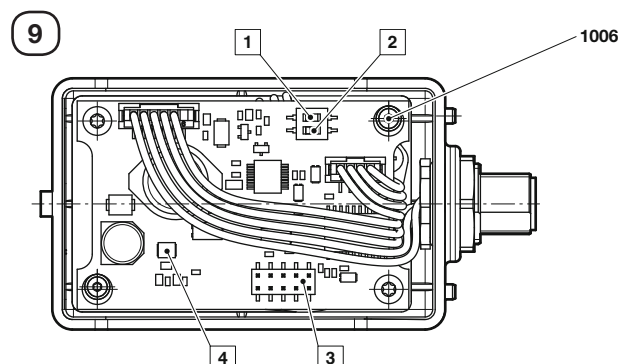

**Dimensions
up to G1/2**

Dimensions in mm
Projection/First angle



10

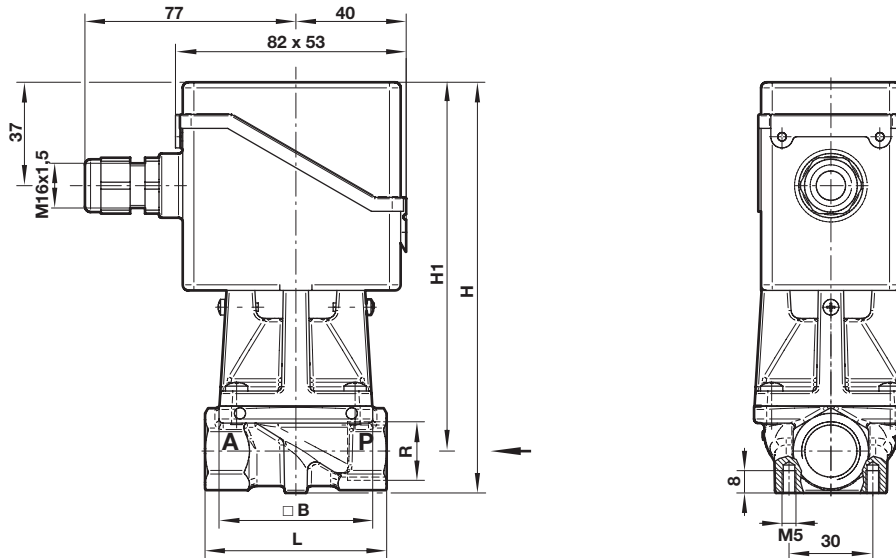

G3/4 ... 1

11

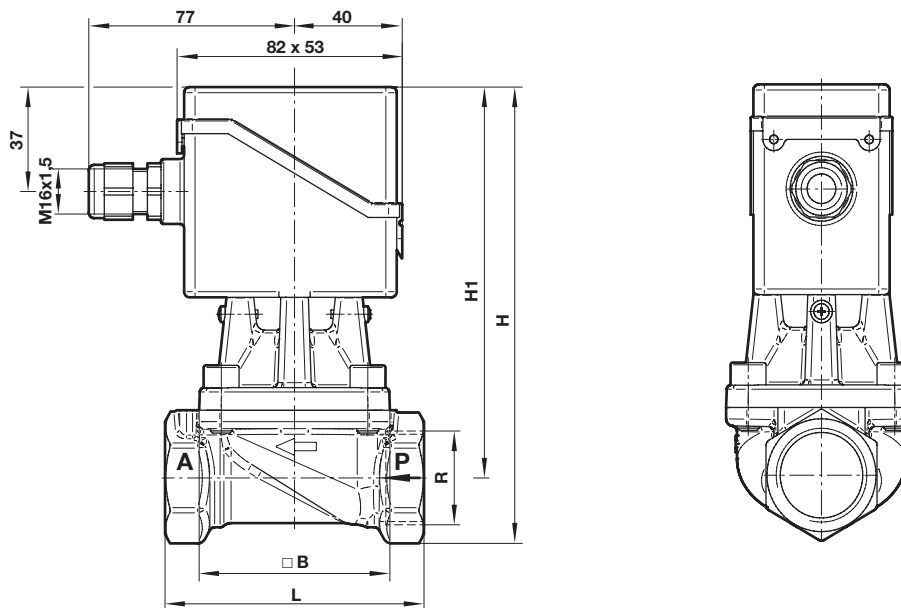

1 60 mm with stepping motor xxxxx.9668.02400

Port size	B	H	H1	L	Model
G1/2	55	147	134	65	8288200.96xx.xxxxx
G3/4	70	164	140	95	8288300.96xx.xxxxx
G1	70	164	140	95	8288400.96xx.xxxxx

Note to Pressure Equipment Directive (PED):

The valves of this series are according to Art. 4 § 3 of the Pressure Equipment Directive (PED) 2014/68/EU. This means interpretation and production are in accordance to engineers practice wellknown in the member countries. The CE-sign at the valve does not refer to the PED. Thus the declaration of conformity is not longer applicable for this directive.

Note to Electromagnetic Compatibility Guideline (EEC):

The valves shall be provided with an electrical circuit which ensures the limits of the harmonised standards EN 61000-6-3 and EN 61000-6-1 are

Note to EAC marking:

The EAC-marked products comply with the applicable requirements stated in the technical regulations of the Eurasian Economic Union.